

JOINT STOCK COMPANY
«PRODUCTION ASSOCIATION ELABUGA AUTOMOTIVE WORKS»

CATALOGUE OF PRODUCTS



OUR STRENGTH - IN UNITY, SUCCESS – IN COOPERATION!

www.elaz.ru



ABOUT THE COMPANY

For more than 35 years JSC «PA ELAZ» conducts business in the sphere of production of wide range of oil and gas extraction industry, road construction, and municipal special machinery. Unique model range of special machinery, hi-tech mobile units and rigs, street cleaners on truck chassis, and ELAZ BL backhoe loaders have been developed and implemented for oil and gas complex under import substitution.

JSC «PA ELAZ» is a member of Russian alliance of gas and oil equipment producers and enters three top leader-producers of mobile equipment for boreholes drilling, repair, and maintenance.

In a year 2005, ELAZ team was awarded State Prize of the Republic of Tatarstan in the sphere of science and technology for development and production of oil and gas boreholes repairing aggregates.

Innovative ideas and know-how ensure product range update implementing advanced engineering solutions and technologies. Targeting Customers' demands, ELAZ continuously improves operating characteristics of produced machines.

Design and Process Departments ensure meeting all unique production targets. Mentioned

services conduct designing activities as per all operations of the Company based on advanced software applications as well as 3D simulation and strength analysis.

Quality is a strategic target of the Company. In a year 2003, ELAZ Quality Management System was certified as complying with ISO 9001-2001. So far, ELAZ is certified as complying with GOST ISO 9001-2015.

ELAZ extends cooperation with Russian Consumers and conducts intense activity with partners from following CIS (Kazakhstan, Uzbekistan, Azerbaidzhan, and Turkmenistan) and non-CIS countries. Our Customers are largest petroleum and gas extraction enterprises such as PJSC Gazprom, PJSC NK Rosneft, PJSC Lukoil, PJSC Tatneft, PJSC Gazpromneft.

ELAZ ensures service and warranty maintenance of special machinery. Service support is executed by service team and certified centers. Consultancy and warranty repair applications reception are carried out 24/7. Only OEM parts are used for warranty and service maintenance.

Corporate strategy aims to focus on increasing of production volumes, development, and scaling-up of model range.

QUALITY
RELIABILITY
STABILITY
COMPETENCE

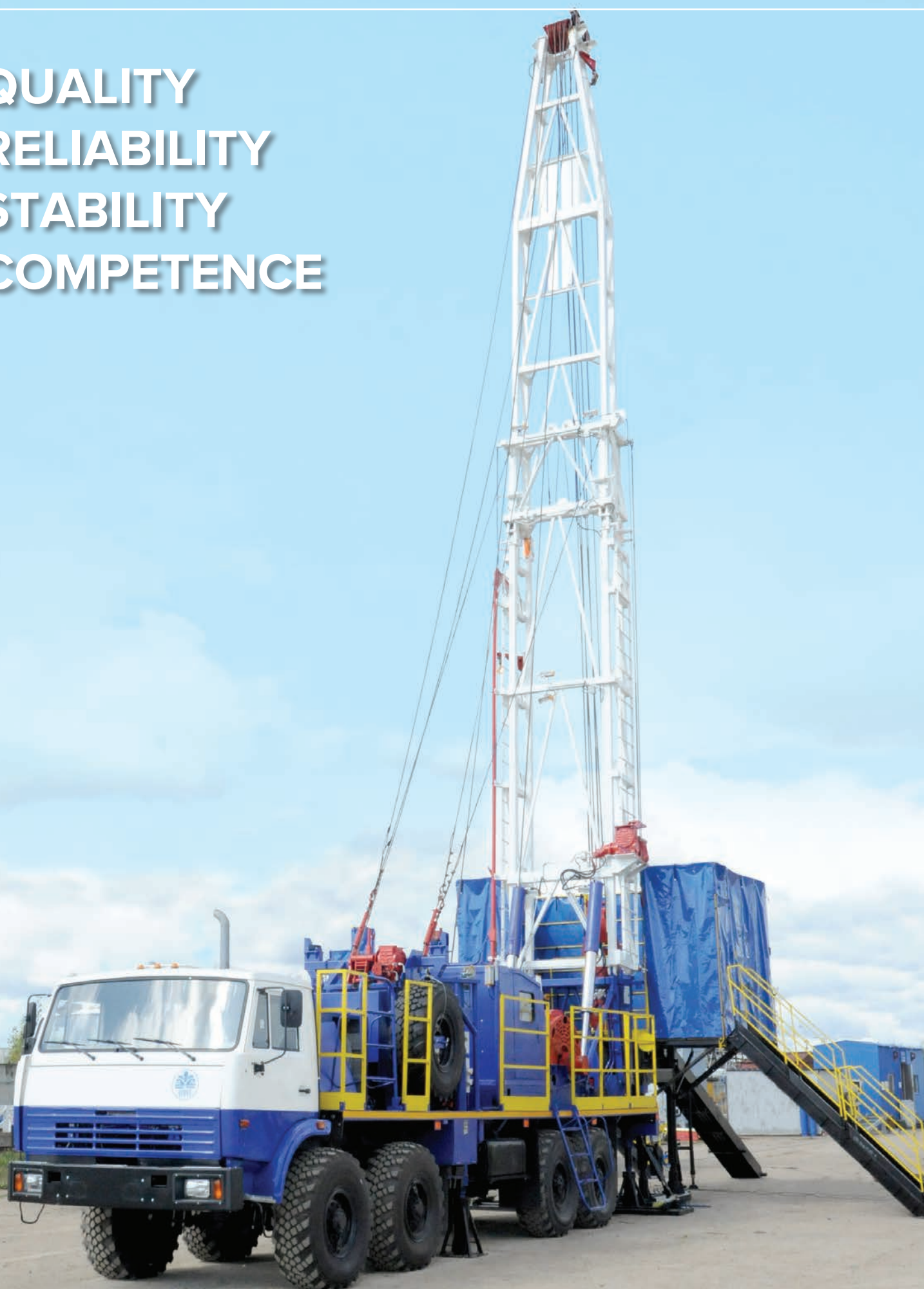

OUR ADVANTAGES

35 years of experience



INDIVIDUAL APPROACH
TO EACH
CLIENT



CERTIFIED QUALITY
MANAGEMENT
SYSTEM



OUR OWN
DESIGN
OFFICE



LEAN
MANUFACTURING
SYSTEM



PROFESSIONAL
SERVICE AND WARRANTY
SERVICE



HIGH-TECH
EQUIPMENT



OWN
DEVELOPMENTS



SPECIAL MACHINERY FOR OIL AND GAS INDUSTRY



HOISTING UNIT FOR BOREHOLES REPAIR	APRS-12
HOISTING UNIT FOR BOREHOLES REPAIR	APRS-18
PROSPECTING DRILLING UNIT	URB-30
HOISTING UNIT FOR BOREHOLES REPAIR	APRS-32/40
HOISTING UNIT FOR DEVIATED BOREHOLES REPAIR	APRS-40N
HOISTING UNIT FOR BOREHOLES REPAIR ON KAMAZ TRUCK CHASSIS BASE	APRS-40KAM
HOISTING UNIT FOR BOREHOLES REPAIR ON URAL TRUCK CHASSIS BASE	APRS-40M
HOISTING UNIT FOR BOREHOLES DRILLING AND REPAIR ON PPS-4 SELF-PROPELLED CHASSI	APRS-40C4
HOISTING UNIT ON PPS 4 SELF-PROPELLED CHASSIS BASE	APRS-40-C4
HOISTING UNIT FOR BOREHOLES REPAIR ON SEMITRAILER BASE	APRS-50P
HOISTING UNIT FOR BOREHOLES REPAIR ON KAMAZ TRUCK CHASSIS BASE	APRS-50KAM
HOISTING UNIT FOR BOREHOLES REPAIR ON RKR TRUCK CHASSIS BASE	APRS-50K
HOISTING UNIT FOR BOREHOLES REPAIR ON PPS-4 SELF-PROPELLED CHASSIS	APRS-50C
HOISTING UNIT FOR BOREHOLES REPAIR ON SEMI-TRAILER BASE	APR-60/80P
HOISTING UNIT FOR BOREHOLES REPAIR ON KAMAZ TRUCK CHASSIS BASE	APR-60/80
HOSITING UNIT FOR BOREHOLES REPAIR ON RKR TRUCK CHASSIS BASE	APR-60/80
HOISTING UNIT FOR BOREHOLES REPAIR ON SEMITRAILER BASE	APR-80P
HOSITING UNIT FOR BOREHOLES REPAIR ON KAMAZ TRUCK CHASSIS BASE	APR-80
HOISTING UNIT FOR BOREHOLES REPAIR ON RKR TRUCK CHASSIS BASE	APR-80
HOISTING UNIT FOR BOREHOLES REPAIR ON MZKT TRUCK CHASSIS BASE	APR-80
HOISTING UNIT FOR BOREHOLES REPAIR ON PPS-5 SELF-PROPELLED CHASSIS BASE	APR-80
HOISTING UNIT FOR BOREHOLES DRILLING AND REPAIR ON SEMITRAILER BASE	UPR-100P
HOISTING UNIT FOR BOREHOLES REPAIR AND DRILLING ON KRAZ TRUCK CHASSIS BASE	UPR-100
HOISTING UNIT FOR BOREHOLES REPAIR AND DRILLING ON PPS-5 SELF-PROPELLED	UPR-100
HOISTING UNIT FOR BOREHOLES REPAIR AND DRILLING ON MZKT TRUCK CHASSIS	UPR-100
MOBILE HOISTING UNIT FOR BOREHOLES DRILLING AND REPAIR ON SEMITRAILER BASE	UPRB-125
MOBILE HOISTING UNIT FOR BOREHOLES DRILLING AND REPAIR ON MZKT TRUCK CHASSIS	UPRB-125
MOBILE HOISTING UNIT FOR BOREHOLES DRILLING AND REPAIR ON BAZ TRUCK CHASSIS BASE	UPRB-125
MOBILE HOISTING UNIT FOR BOREHOLES REPAIR AND DRILLING	UPRB-140
INTEGRATED COILED TUBING UNIT WITH PORTAL TYPE DERRICK	UKPT-10
CEMENTING UNIT ON SEMITRAILER BASE	ATs-32
CEMENTING UNIT WITH TRIPLEX PLUNGER PUMP	ATs-32
CEMENTING UNIT WITH PISTON CEMENTING PUMP	ATs-32
MIXING UNIT	US 20x50
MIXING UNIT	US 16
EVACUATION OIL SKIMMER	AKN-10

APRS-12

HOISTING UNIT FOR BOREHOLES REPAIR



Lifting unit for boreholes repair APRS-12 (further –Unit), is designed for boreholes overhaul repair, with possibility of derrick adjustment and centering, ESP unit (electrical submersible pump unit) and rod cavity pump roundtrip.

The unit provides the following operations:

- mobile travel from borehole to borehole using tractor or vehicle;
- mounting and dismounting operations at borehole;
- round-trip operations with tubing strings and deep-well pumping rod;
- tubing strings mechanical make-up and break-out $\varnothing 48...89$ and deep-well pumping rod $\varnothing 16...25$ mm using hydraulic wrench;
- cleaning of sand plugs with cleanout bailer and boreholes development.

The unit is mounted on trailer PS85712 chassis and is used in moderate climate conditions.

Climatic version-U, arrangement category I acc. to GOST 15150-69 at working temperature of ambient air from -45° to $+40^{\circ}$ C (ambient temperature upper limit from -50° C to $+45^{\circ}$ C).

Mounting base, chassis	Two-axle trailer PS85712
Loading capacity on tackle block, kN (tf)	
- nominal	120 (12)
Drive	PD-130
Engine	diesel YAMZ -236M2
Derrick	Two- section, front open faced
- height to crownblock sheaves, m	18
- lifting in working position	By hydraulic jack
- angle of lean, degrees	40
- fixing of derrick in working position	Unit for anchor-free fixing and guy system for fixing to outer anchors
Main winch	Single drum, with reverse and pressure roller
- winch brake	Hydraulic, disc
- dia of hoist wireline, mm	16
- control	From control panel
Pulley-block system	Two-string
- tooling	2x1
Round-trip operation control	Hydraulic; travelling block limit switch; overload protection travelling block; hydraulic winch brake, controlled from panel at rear platform
Hook travel speed, m/s	
- max/min	1,0/0,2
Unit operating system power	From diesel engine generator, storage battery and from AC supply, 220 V, in addition
Travel speed, km/h, not more than	40
Obstacles crossing parameters, degrees, not more than	
- ascents/descents/slopes	25/25/15
limiting dimensions in transport position together with tractive vehicle, mm, not more than	
- length/width/height	20000/2500/4000
Total unit weight, kg	11600



The lifting unit APRS -18 for repair of deviated boreholes (hereinafter - unit) is designed for boreholes overhaul repair, with possibility of derrick adjusting and aligning, ESP (electrical submersible pump unit) and rod screw pumps round trip.

The unit allows the following operations:

- mobile movement from borehole to borehole with the help of tractor or vehicle;
- rig-down and rig-up operations on borehole;
- round trip by tubing strings and subsurface pumping rods;
- tubing strings diameter 48...89 and subsurface pumping rods diameter 16...25 mm mechanical make-up and break-out using hydraulic wrench;
- bailing of well sand plug and boreholes development.

The unit is mounted on PS85712 trailer chassis and is operated in moderate climate.

Climatic version - U, location category - 1 as per GOST 15150-69 at ambient air operating temperature from minus 45°C to plus 40°C (ambient air temperature limits -50° C to + 45°C).

Mounting base, chassis	Two-axle trailer SPTE94170
Traveling block loading capacity kN (tf)	
- nominal	180(18)
- short time	240 (24)
Drive	PD-130 (YAMZ-236HE)
Primary winch:	Hydraulic, reverse, with wire damper.
- line-carrying capacity, m	80
- traction force, N	6000
- winch brake	Hydraulic, disc
Telescopic derrick:	Two-section, front open faced
- height to crownblock sheave axis, m	18
- hook lifting height, m	14
- derrick installation control	Hydraulic
tackle system (tooling)	four-string (3x2)
Max. lifting speed (up to 9.5t), m/s	0,7
Max. lifting speed (with 24 t), m/s	0,4
Electric equipment:	
- unit operating system supply	From diesel engine generator, battery and additionally from AC supply 220 V
- lighting service	
Hydraulic system:	double-circuit
pressure circuit (closed)	Winch drive
- adjustable pump 416.0.125 - 1 un.	
- variable drive motor 303.4.160 - 1 un.	
Mounting circuit (open)	Outriggers extension, derrick lifting
- gear pump -50 - 1 un.	
Overall dimensions in transport position:	
- length, mm, not more than	11000
- width, mm, not more than	2500
- height, mm, not more than	3800
- total weight, kg, not more than	18000

URB-30

PROSPECTING DRILLING RIG



The unit URB-30 is designed for structure drilling for oil and gas by rotor in soft and average hard rocks with direct flushing and water borehole drilling in moderate macroclimatic regions with ambient temperature from -45 °C to +40°C.

Basic equipment includes power swivel BA-15, pump NB-50, rotor R-410, racking platform, generator GS-250, operator's platform 2000x1500 mm.

Mounting base	URAL 4320	KAMAZ 43118
Chassis engine-diesel, turbocharged	YAMZ 236NE2	KAMAZ -740
- capacity, hp	300	280
Loading capacity on tackle block, kN (tf)		
- nominal		300(30)
Height to crownblock axis, m		18.5
Derrick	telescopic, 2- section derrick, front open faced	
- raising in operation position	by hydraulic jacks	
- extension of top section	by wireline, special winch with hydraulic drive	
- fixing of derrick in operation condition	guy lines for fastening to external anchors	
Masting control	hydraulic remote	
Power take-off, hp		100
Hook travel speed, m/s		0.15...1.42
Main winch	single drum	
- dia of hoist wireline mm		22
Brake	shoe	
- number of brake pulleys		1
- brake control	foot pneumatic and manual mechanical	
Auxiliary winch	hydraulic	
- nominal line pull, tf		3.0
Tackle system	4-string	
- tooling	3x4	
Overall dimensions, mm:		
- length	11400	10300
- width	2500	2500
- height	4450	4000
Unit weight (not more), kgf	16400	16400



Hoisting unit APRS -32/40 is designed for oil and gas wells servicing and development in moderate macroclimatic regions with ambient temperature from -45° to $+40^{\circ}$ C.

Main design features and service advantages:

- transfer from borehole to another by tractor unit;
- erection and dismantling operations;
- lowering and lifting operations with oil-well tubing and pump rods;
- make-up and break-out of tubing and bottomhole pumping rods.

Climatic version-U, arrangement category-1 acc to GOST 15150-69 at working temperature of ambient air from -45° C to $+40^{\circ}$ C.

As well as the unit is suitable for cold macroclimatic region 12 acc. to GOST16350.

Mounting base	Semitrailer 2 axis SPTE94170
Hook load capacity, kN (tf)	
- nominal	313,6 (32)
Short time maximum permissible, kN (tf)	392 (40)
Drive	YAMZ-238M2
Main draw works	Single drum
Force exerted rating, kN (tf)	65,7 (6,7)
Dia of hoist wireline	22
Brake	disc (2 pcs)
Brake control	remote control
Hook travel speed, m/s	
- max/min	1,42/0,15
Derrick	2-section derrick, front open faced
The height from ground to crownblock axis	18
Tackle system	Tooling 3X4
Electrical equipment	Powered from chassis generator, battery and line supply 220V
Hydraulic system	Single-circuit
	20(200)-while hydraulic tongs operation
- Operating pressure no more than MPa (kg/cm ²)	116(160) while operation of outriggers, mast lifting hydraulic jack, auxiliary draw works, draw works lifting, upper section extension
Limiting dimensions in transport position with tractive vehicle, mm, not more than:	
- length	16000
- width	2500
- height	4000
Loaded weight, kg, not more than	21000

APRS-40N

HOISTING UNIT FOR DEVIATED BOREHOLES REPAIR



The unit is designed for well servicing with arrangement of wellhead at 45 ° -75 °, relatively to the ground surface, including performance of tripping operations with deep-well pumping rods sh22, 25 mm and oil-well tubing sh48, 60, 73, 89 mm, mechanized screwing and unscrewing of rods and pipes using hydraulic wrench, mounting and dismantling of wellhead equipment and blowout-prevention equipment.

In the unit design is envisaged the mobile system of derrick alignment relatively to the wellhead in 3-x coordinates.

Mounting base	Semi SPTЕ 94163, 3-axis
Chassis engine	YAMZ -238M2 with gearbox YAMZ -236
Loading capacity in inclined position, kN (tf)	200 (20)
Derrick	Inclined, front open faced, single section
Derrick raising system	telescopic hydraulic cylinder powerblock, single drum, with possible reverse, the drum clutch with Lebus grooves
Main winch	
- dia of hoist wireline mm	22
Actuating winch	hydraulic, loading capacity 6.8 t
Auxiliary winch (2 units)	hydraulic, loading capacity 2 t
Hydraulic tongs	GKSh-1200MT
Racking platform	capacity-135 pipes 73 mm length 9.3-11.5 m
Overall dimensions, mm:	
- length	20000
- width	2500
- height	4400
Total unit weight (not more), kgf	32600

APRS-40 KAM

HOISTING UNIT FOR BOREHOLES REPAIR ON KAMAZ TRUCK CHASSIS BASE



The unit is designed for oil and gas wells servicing and development in moderate macroclimatic regions with ambient temperature from - 45° C to +40° C.

Main design features and service advantages:

- high mobility during erection and dismantling operations due to availability of front and rear outriggers for unit rigging up;
- derrick rear support is made as separate part thus excluding load moving towards unit chassis during operation;
- spring -type brake in brake system prevents lowering- in of tackle block during long time parking;
- shipping dimensions are observed;
- comfortable heated operator's cab is available.

Mounting base	KAMAZ 43118
Loading capacity on hook, kN (tf)	
- nominal	400 (40)
Height to crownblock axis, m	18.5 (19.5)
Derrick	telescopic 2- section, with open front side
Drive	from vehicle traction engine
Round trip operations control	electro pneumatic and manual mechanical from cab on the unit platform
Hook travel speed, m/s	
- max/min	0,22/1,42
Tackle system	6- string
- tooling	3x4
Main winch	single drum
- dia of hoist wireline, mm	22
Brake	band and shoe
- number of brake pulleys	1
Transmission	three-speed
Overall dimensions, mm	
- length	10300
- width	2500
- height	4000
Unit weight (not more), kgf	20000

On customer's request, the unit can be additionally equipped with wellhead service platform and catwalk. Supply of any spare parts is guaranteed.

APRS-40 M

HOISTING UNIT FOR BOREHOLES REPAIR ON URAL TRUCK CHASSIS BASE



The unit is designed for oil and gas boreholes servicing and development in moderate macroclimatic regions with ambient temperature from - 45° C to +40° C.

Main design features and service advantages:

- high mobility during erection and dismantling operations due to availability of front and rear outriggers for unit rigging up;
- derrick rear support is made as separate part thus excluding load moving towards unit chassis during operation;
- spring brake in brake system prevents lowering- in of tackle block during long stay;
- shipping dimensions are observed;
- comfortable heated operator's cab is available.

Mounting base	URAL 4320
Loading capacity on hook, kN (tf)	
- nominal	400 (40)
Height to crownblock axis, m	18.5 (19.5)
Derrick	telescopic 2- section, with open front side
Drive	from vehicle traction engine
Round trip operations control	electro pneumatic and manual mechanical from cab on the unit platform
Hook travel speed, m/s	
- max/min	0,22/1,42
Tackle system	6- string
- tooling	3x4
Main winch	single drum
- dia of hoist wireline, mm	22
Brake	band and shoe
- number of brake pulleys	1
Transmission	three-speed
Overall dimensions, mm	
- length	11000
- width	2500
- height	4000
Unit weight (not more), kgf	22500

On customer's request, the unit can be additionally equipped with wellhead service platform and catwalk. Supply of any spare part is guaranteed.



The unit APRS-40C4 is designed for rotary drilling by bottomhole flushing for soft and medium formation of stratigraphic test well, as well as boreholes repair where maximum load doesn't exceed 'allowable load on hook' parameter according to its loading capacity.

Rig enables to execute following operations:

- transfer from one borehole to another;
- erection and dismantling operations on borehole;
- lowering and lifting operations with oil-well tubing and pump rods;
- boreholes drilling;
- fishing and other types of work, boreholes liquidation;
- sand plugs and cement columns drilling out;
- development of boreholes after drilling.

Mounting base	4-axis traveling self-propelled platform PPS-4
- wheel arrangement	8x8.1+1
- engine	YAMZ-238B-1 (Euro-0)
- nominal rating power, kW (h.p.)	221 (300)
Allowable load on hook block, kN (tf)	392 (40)
Height from the ground to crown block axis	19,5
Operator's cab	Engine, chassis, drawworks control
Tackle system	
- tooling	3x4
Draw works	Single-drum, gear drive, mechanical
Electrical equipment	24 V from generator unit and battery
Assembled weight, kg no more than	27600
- on front 2-axis group, kg not more than	12600
- rear 2-axis group, kg not more than	15000

APRS-50P

HOISTING UNIT FOR BOREHOLES DRILLING AND REPAIR ON SEMITRAILER BASE



The unit is designed for oil and gas boreholes development, overhaul repair and servicing in moderate macroclimatic regions with ambient temperature from -45° C to +40° C.

Main design features and service advantages:

- high mobility during erection and dismantling operations due to availability of front and rear outriggers for unit rigging up;
- derrick rear support is made as separate part thus excluding load moving towards unit chassis during operation;
- spring brake in brake system prevents lowering- in of tackle block during long stay;
- availability of different developed designs of systems and units for specific operating environment on the customer's choice ("limit switch", rotary drive, rope bypassing mechanism, emergency drive, operator's platform, driller's station and etc.);
- possibility of working operations control from operator's cab and driller's station;
- shipping dimensions are observed;
- modified versions of the units with observed «height clearance»;
- increased reliability due to elimination of track drive transmission;
- operating costs reduction.

Mounting base	Semi trailer TSP 94163-000010
Hook load capacity, kN (tf)	
- nominal	500 (50) (without guy wire)
Height to crownblock axis, m	21,5
Derrick	telescopic 2- section, with open front side
Drive	diesel PD-150-16 with YAMZ-238 M2 engine
Round trip operations control	electro pneumatic and manual mechanical from operator's cab
Hook travel speed, m/s	
- max/min	1,42/0,15
Tackle system	6- string
- tooling	3x4
Main winch	single drum
- dia of hoist wireline, mm	25
Brake	band and shoe
- number of brake pulleys	2
Transmission	three-speed
Overall dimensions, mm	
- length	13000
- width	2550
- height	3950
Unit weight (not more), kgf	21000

APRS-50 KAM

HOISTING UNIT FOR BOREHOLES DRILLING AND REPAIR ON KAMAZ TRUCK CHASSIS BASE



The unit is designed for oil and gas boreholes development, overhaul repair and servicing in moderate macroclimatic regions with ambient temperature from -45° C to +40° C.

Main design features and service advantages:

- high mobility during erection and dismantling operations due to availability of front and rear outriggers for unit rigging up;
- derrick rear support is made as separate part thus excluding load moving towards unit chassis during operation;
- spring brake in brake system prevents lowering- in of tackle block during long stay;
- availability of different developed designs of systems and units for specific operating environment on customer's choice («limit switch», rotary drive, rope bypassing mechanism, emergency drive, operator's platform, driller's station and etc.);
- possibility of working operations control from operator's cab and driller's station;
- shipping dimensions are observed.

By customer's request, it can be additionally equipped with:

- driller's station and hydraulic-mechanical rotor, operator's platform, catwalks.

Mounting base	KAMAZ 65111, KAMAZ 6522	KAMAZ-65224- 0003970-43
Hook load capacity, kN (tf)	500 (50) (without guy wire)	490 (50) (without guy wire)
Height to crownblock axis, m	21,5	24
Derrick	telescopic 2- section, front open faced	
Drive	from vehicle traction engine	two-speed chain-drive motor reducer with pressure shell (with oil sump)
Hook travel speed, m/s		
- max/min	1,42/0,15	1,5/0,08
Tackle system	6- string	
- tooling	3x4	
Main winch	single drum	single drum, chain gearing, geared with cable layer
- dia of hoist wireline, mm	25	
Auxiliary winch	hydraulic	
- loading capacity, tf	1,6	
Brake	band and shoe	
- number of brake pulleys	2	
Gear box	three-speed	
Overall dimensions, mm		
- length	11500	12675
- width	2500	2550
- height	4000	4200
Unit weight, kgf	25200	30125

APRS-50K

HOISTING UNIT FOR BOREHOLES DRILLING AND REPAIR ON RKR TRUCK CHASSIS BASE



The unit is designed for oil and gas boreholes development, overhaul repair and servicing in moderate macroclimatic regions with ambient temperature from -45°C to $+40^{\circ}\text{C}$.

Main design features and service advantages

- high mobility during erection and dismantling operations due to availability of front and rear outriggers for unit rigging up;
- derrick rear support is made as separate part thus excluding load moving towards unit chassis during operation;
- spring brake in brake system prevents lowering- in of tackle block during long stay;
- availability of different developed designs of systems and units for specific operating environment on the customer's choice («limit switch», rotary drive, rope bypassing mechanism, emergency drive, operator's platform, driller's station and etc.);
- possibility of working operations control from operator's cab and driller's station;
- shipping dimensions are observed.

By customer's request, it can be additionally equipped with:

- driller's station and hydraulic-mechanical rotor, operator's platform, catwalks;
- bailing winch (can be mounted instead of driver's cabin)

Mounting base	PKP-63221-4320
Hook load capacity, kN (tf)	500 (50) (without guy wire)
Height to crownblock axis, m	21,5
Derrick	telescopic 2- section, front open faced
Drive	from vehicle traction engine
Hook travel speed, m/s	
- max/min	1,42/0,15
Tackle system	6- string
- tooling	3x4
Main winch	single drum
- dia of hoist wireline, mm	25
Auxiliary winch	hydraulic
- loading capacity, tf	1.6
Brake	band and shoe
- number of brake pulleys	2
Transmission	three-speed
Overall dimensions, mm	
- length	11500
- width	2500
- height	4000
Unit weight (not more), kgf	26000



The unit APRS-50C is designed for oil and gas oil and gas wells repair and development considering depth value where max loads as well as while failures (salvage operation) don't exceed 'allowable load on hook' parameter according to its loading capacity.

Rig enables execution of following operations:

- moving from one borehole to another;
- erection and dismantling activities;
- lowering and lifting operations with oil-well tubing and pump rods;
- fishing and other types of work;
- boreholes liquidation;
- sand plugs and cement columns drilling out;
- milling of metal parts;
- development of boreholes after drilling etc.

Climatic version-U, arrangement category-1 acc. to GOST 15150-69 at working temperature of ambient air from - 45°C to 40°C (ambient air temperature limits from -50°C to 45°C).

Mounting base	4-axis traveling self-propelled platform PPS-4
- wheel arrangement	8x8.1+1
- engine	YAMZ-238B-1 (Euro-0)
- nominal rating power, kW (h.p.)	221 (300)
Allowable load on hook block, kN (tf)	490 (50)
Height from the ground to crown block axis	24
Operator's cab	Engine chassis, drawworks control
Tackle system	
- tooling	3x4
Draw works	Single-drum, gear drive, mechanical
Electrical equipment	24 V from generator unit and battery
Assembled weight, kg no more than	30700
- on front 2-axis group, kg no more than	12900
- rear 2-axis group, kg no more than	17800

APR-60/80P

HOISTING UNIT FOR BOREHOLES REPAIR ON SEMITRAILER BASE



The unit is designed for oil and gas boreholes development, overhaul repairing, and well servicing in moderate macroclimatic regions with ambient temperature from - 45°C to 40°C.

Main design features and service advantages:

- high mobility during erection and dismounting operations by front and rear outriggers for rig up.
- derrick rear support is made as separate part thus excluding load moving towards unit chassis while operation;
- spring brake prevents tackle system from lowering during long stay;
- wide range of systems and units as per Customer's requirements (limit switch, rotary drive, rope bypassing mechanism, emergency drive, operator's platform, driller's station etc.)
- operations control from operator's cab as well as from driller's station;
- modified versions of the units with observed height clearance.
- advanced reliability due to exclusion of chassis drive transmission;
- operating costs decrease.

Mounting base	Semitrailer SPT 99100
Hook load capacity, kN (tf)	
- nominal	600 (60)
- momentary, max allowable	800 (80)
Drive	Diesel PD-150-16c Engine YAMZ-238 M2
Primary draw works	Single drum
- dia of hoist wireline	25
Brake	Band and shoe
- the number of pulleys	2
Auxiliary draw works	Hydraulic
- loading capacity, tf	1,6
Derrick	Telescopic 2-section with open front end
Height to crownblock axis,m	21,5
Tackle system/tooling	6-string/3x4
Round trip operations control	Electro-pneumatic, manual mechanical control from operator's cab
Operator's cab heating system	Heater electrical flame proof
Overall dimensions, mm	
- length	13000
- width	2550
- height	3950
Rig weight (not more than), kgf	21000



The unit is designed for oil and gas boreholes development, overhaul repair and servicing in moderate macroclimatic regions with ambient temperature from -45° C to +40° C.

Main design features and service advantages:

- high mobility during erection and dismantling operations due to availability of front and rear outriggers for unit rigging up;
- derrick rear support is made as separate part thus excluding load moving towards unit chassis during operation;
- spring brake in brake system prevents lowering- in of tackle block during long stay;
- availability of different developed designs of systems and units for specific operating environment on the customer's choice («limit switch», rotary drive, rope bypassing mechanism, emergency drive, operator's platform, driller's station and etc.);
- possibility of working operations control from operator's cab and driller's station;
- modified versions of the units with observed «height clearance».

Mounting base	KAMAZ 6522
Loading capacity on tackle block, kN (tf)	
- nominal	600 (60)
- short time maximum permissible	800 (80)
Height to crownblock axis, m	22,6
Derrick	telescopic, 2- section derrick, front open faced
- fixing of derrick in operation condition	device for anchor-less fastening, guy line system for fastening to external anchors
Hook travel speed, m/s	
- max/min	1,42/0,15
Tackle system	6- string
- tooling	3x4
Main winch	single drum
- dia of hoist wireline mm	25
Auxiliary winch	hydraulic
- loading capacity, tf	1,6
Brake	shoe
- number of brake pulleys	2
Transmission	three-speed
Overall dimensions, mm	
- length	12700
- width	2500
- height	4000
Unit weight (not more), kgf	29400

APR-60/80

HOISTING UNIT FOR BOREHOLES REPAIR ON RKR TRUCK CHASSIS BASE



The unit is designed for oil and gas boreholes development, overhaul repair and servicing in moderate macroclimatic regions with ambient temperature from -45° C to +40° C.

Main design features and service advantages:

- high mobility during erection and dismantling operations due to availability of front and rear outriggers for unit rigging up;
- derrick rear support is made as separate part thus excluding load moving towards unit chassis during operation;
- spring brake in brake system prevents lowering- in of tackle block during long stay;
- availability of different developed designs of systems and units for specific operating environment on the customer's choice («limit switch», rotary drive, rope bypassing mechanism, emergency drive, operator's platform, driller's station and etc.);
- possibility of working operations control from operator's cab and driller's station;
- modified versions of the units with observed «height clearance».

Mounting base	RKR-63221-4320
Hoisting block load capacity, kN (tf)	
- nominal	600 (60)
- momentary, max allowable	800 (80)
Height to crownblock axis, m	22,6
Derrick	telescopic 2-section with open front side
- derrick securing in operation position	anchor-free securing device, derrick guy system for fixing to outer anchors
Hook traveling speed, m/s	
- max/min	1,42/0,15
Tackle system	6-string
- tooling	3x4
Primary draw works	single drum
- wireline diameter, mm	25
Auxiliary draw works	hydraulic
- loading capacity, tf	1,6
Brake	shoe
- brake pulleys number	2
Transmission	3-speed
Overall dimensions, mm	
- length	13000
- width	2500
- height	4000
Rig weight (not more than), kgf	29600



The unit is designed for oil and gas boreholes development, overhaul repair and servicing in moderate macroclimatic regions with ambient temperature from -45° C to +40° C.

Main design features and service advantages

- high mobility during erection and dismantling operations due to availability of front and rear outriggers for unit rigging up;
- derrick rear support is made as separate part thus excluding load moving towards unit chassis during operation;
- spring brake in brake system prevents lowering- in of tackle block during long stay;
- the unit is equipped with racking platform adjustable in three positions for operation with double stands.
- availability of different developed designs of systems and units for specific operating environment on the customer's choice («limit switch», rotary drive, rope bypassing mechanism, emergency drive, operator's platform, driller's station and etc.).

Additional equipment- as per order. It can be equipped with PS85 power swivel (of «Logan Oil Tools «Inc. USA production; authorized distributor in Russia –LLC «Heftepromservis».

Mounting base	Semitrailer TSP 94 163-000030
Loading capacity on tackle block, kN (tf)	
- nominal	800 (80)
Height to crownblock axis, m	32
Derrick	telescopic, 2- section derrick, front open faced, with racking platform
- fixing of derrick in operation condition	guy line system for fastening to external anchor
Winch drive	from deck engine
Hook travel speed, m/s	
- max/min	1,42/0,15
Tackle system	6- string
- tooling	3x4
Main winch	single drum powerblock, improved (reinforced) with two brake rims
- dia of hoist wireline mm	25
Auxiliary winch	hydraulic
- nominal line pull, tf	3,0
Brake	shoe
- number of brake pulleys	2
Transmission	three-speed
Wellhead low working platform	
- overall dimensions, mm	5000x4000
- adjustable height, m	up to 6
Overall dimensions, mm	
- length	18600
- width	2750
- height	4440
Unit total weight (not more), kgf	40000

APR-80

HOISTING UNIT FOR BOREHOLES REPAIR ON KAMAZ TRUCK CHASSIS BASE



The unit is designed for oil and gas boreholes development, overhaul repair and servicing in moderate macroclimatic regions with ambient temperature from -45°C to $+40^{\circ}\text{C}$.

Main design features and service advantages

- high mobility during erection and dismantling operations due to availability of front and rear outriggers for unit rigging up;
- derrick rear support is made as separate part thus excluding load moving towards unit chassis during operation;
- spring brake in brake system prevents lowering- in of tackle block during long stay;
- availability of different developed designs of systems and units for specific operating environment on the customer's choice («limit switch», rotary drive, rope bypassing mechanism, emergency drive, operator's platform, driller's station and etc.);
- possibility of working operations control from operator's cab and driller's station;
- modified versions of the units with observed «height clearance».

Mounting base	KAMAZ 6522
Loading capacity on tackle block, kN (tf)	800 (80)
- nominal	800 (80)
Height to crownblock axis, m	22,6
Derrick	telescopic, 2- section derrick, front open faced, with racking platform
- fixing of derrick in operation condition	guy line system for fastening to external anchor from deck engine
Winch drive	hook travel speed, m/s
Hook travel speed, m/s	- max/min
- max/min	1,42/0,15
Tackle system	6- string
- tooling	3x4
Main winch	single drum powerblock with two brake rims
- dia of hoist wireline mm	25
Auxiliary winch	hydraulic
- nominal line pull, tf	1,6 (3,0)
Brake	shoe
- number of brake pulleys	2
Transmission	three-speed
Wellhead low working platform:	
- overall dimensions, mm	3000x4000
- adjustable height, m	1,0 - 3,0
Overall dimensions, mm	
- length	13120
- width	2500
- height	4300
Unit total weight (not more), kgf	30000



The unit is designed for oil and gas boreholes development as well as overhaul repairing in moderate macroclimatic regions with ambient temperature from - 45°C to 40°C.

Main design features and service advantages:

- high mobility during erection and dismantling operations by front and rear outriggers for rig up.
- derrick rear support is made as separate part thus excluding load moving towards unit chassis while operation;
- spring brake prevents tackle system from lowering during long stay;
- wide range of systems and units as per Customer's requirements (limit switch, rotary drive, rope bypassing mechanism, emergency drive, operator's platform, driller's station etc.)
- operations control from operator's cab as well as from driller's station;
- modified versions of the units with observed height clearance.

Supplementary equipment is provided as per Customer's requirement. Power swivel PS85 is also available (Logan oil tools Inc. USA, authorized distributor in Russia 'Neftepromservice').

Additional equipment- as per order. It can be equipped with PS120 power swivel (of «Logan Oil Tools «Inc. USA production; authorized distributor in Russia –LLC «Heftepromservis»).

Mounting base	RKR-63221-4320
Hoisting block load capacity, kN (tf)	
- nominal	800 (80)
Height to crownblock axis, m	22,6
Derrick	telescopic 2-section with open front side
- derrick securing in operation position	derrick guy system for fixing to outer anchors
Draw works drive	from engine to chassis
Hook traveling speed, m/s	
- max/min	1,42/0,15
Tackle systema	6-string
- tooling	3x4
Primary draw works	Mechanical, single-drum 2 brake rims
- wireline diameter,mm	25
Auxiliary draw works	hydraulic
- nominal traction power, tf	3,0
Brake	shoe
- brake pulleys number	2
Transmission	3-speed
Wellhead lower operation platform	
- overall dimensions, mm	3000x4000
- height aligned, m	1,0 - 3,0
Overall dimensions,mm	
- length	13120
- width	2500
- height	4300
Rig weight (not more than), kgf	30000

APR-80

HOISTING UNIT FOR BOREHOLES REPAIR ON MZKT TRUCK CHASSIS BASE



The unit is designed for oil and gas boreholes development, overhaul repair and servicing in moderate macroclimatic regions with ambient temperature from -45°C to $+40^{\circ}\text{C}$.

Main design features and service advantages:

- high mobility during erection and dismantling operations due to availability of front and rear outriggers for unit rigging up;
- derrick rear support is made as separate part thus excluding load moving towards unit chassis during operation;
- spring brake in brake system prevents lowering- in of tackle block during long stay;
- the unit is equipped with racking platform adjustable in three positions for operation with double stands.
- availability of different developed designs of systems and units for specific operating environment on the customer's choice («limit switch», rotary drive, rope bypassing mechanism, emergency drive, operator's platform, driller's station and etc.).

Mounting base	MZKT- 652716-010
Engine chassis	TMZ-8431.10
Loading capacity on tackle block, kN (tf)	
- nominal	800 (80)
Drive	YAMZ-7511.10
Gearbox	Allison 4700 OFS
Height to crownblock axis, m	24
Derrick	telescopic, 2- section, inclined, front open faced
Derrick raising and extension	by hydraulic jack
- derrick raising and extension control	remote, by special remote console from the ground
Power take-off	wheeled motor traction vehicle
Hook travel speed, m/s	
- max/min	1,45/0,15
Tackle system	6- string
- tooling	3x4
Main winch	single-shaft, single drum, with disc (axial) pneumatic clutch
- dia of hoist wireline, mm	25
Auxiliary winch	hydraulic
- loading capacity, tf	3
Brake	band and shoe
- number of brake pulleys	2
- brake control	foot pneumatic and manual mechanical from driller's station
- hydraulic brake	engagement by disc pneumatic clutch
Overall dimensions, mm	
- length/width/height	13760/2550/4380
Unit weight (not more), kgf	36000



The unit is designed for oil and gas boreholes overhaul repair and development in moderate macroclimatic regions with ambient temperature from -45° C to +40° C.

Basic design features and operational advantages:

- chassis is manufactured on the base of production vehicle chassis "Ural M" main units: IC-engine, gearbox, transmission, axles, suspension, carrier, control units.
- Cabin – of KamAZ vehicle.
- increased competitiveness of special machinery due to lower prices compared to vehicles on vehicle chassis;
- permissible axle loads on the roads (5 axles);
- reliable engine, convenient for operation and maintenance (Euro-0, deck arrangement);
- multipurpose chassis for wide range of special machinery;
- good cross-country ability (4 drive axles, single-tire wheel).

Wheel arrangement	10x8
Engine	YAMZ-238 B-1
Emission standard	Euro-0
Rated power, kW (hp.)	221(300)
YAMZ clutch-182	friction, dry, single disk, with extension type diaphragm spring
KPP -154 gear box	mechanical, three-pass, five-speed, synchromesh for 2-3 and 4-5
Loading capacity on tackle block, kN (tf)	
- nominal	784 (80)
Height to crownblock sheave axis, m	22,0
Derrick	telescopic, two-section, front open faced
- derrick securing in operation position	derrick guy system for fixing to outer anchors
Winch drive	from engine chassis
Main winch	mechanical single drum, with two brake rims
- wireline diameter, mm	25
Auxiliary winch	hydraulic
- force exerted rating, tnf	3,0
Gear box	three speed
Filling value - left/right	300/200
Inter-wheel and interaxial differentials	locking on 3,4 rear buggy axles
Overall dimensions, mm	
- length	11870
- width	2500
- height	3910
Total weight, kg.	32160

УПР-100П

HOISTING UNIT FOR BOREHOLES DRILLING AND REPAIR ON SEMITRAILER BASE



The unit is designed for drilling by rotor and downhole motors of boreholes 2500 m deep (with drill string 24 kg/m), for overhaul repair, development and rehabilitation of oil and gas boreholes up to 5000 m deep (oilwell tubing 14 kg/m) in moderate macroclimatic regions with ambient temperature from -45° C to +40° C.

Main design features and service advantages:

- high mobility during erection and dismantling operations due to availability of front and rear outriggers for unit rigging up;
- derrick rear support is made as separate part thus excluding load moving towards unit chassis during operation;
- spring brake in brake system prevents lowering- in of tackle block during long stay;
- the unit is equipped with racking platform, adjustable in three positions for double stands
- availability of different developed designs of systems and units for specific operating environment on the customer's choice («limit switch», rotary drive, rope bypassing mechanism, emergency drive, operator's platform, driller's station and etc.);
- possibility of working operations control from operator's cab and driller's station;
- modified versions of the units with observed «height clearance»;
- increased reliability due to elimination of track drive transmission;
- operating costs reduction.

Mounting base	Semitrailer TSP 948406-0000010	Semitrailer TSP 94163-0000030
Hook load capacity, kN (tf)		
- nominal	1000 (100)	981 (100)
Height to crownblock axis, m	30	32
Derrick	telescopic, 2- section derrick, front open faced	
Drive	from power take-off device by cardan shaft	
Round trip operations control	electro-pneumatic and manual mechanical control from operator's cab	
Hook travel speed, m/s		
- max/min		1,42/0,15
Tackle system		8- string
- tooling		4x5
Main winch		single drum, with cut grooves for rope
- dia of hoist wireline mm		25
Brake		band and shoe
- number of brake pulleys		2
Transmission		three-speed
Overall dimensions, mm		
- length		19500
- width		3000
- height		4500
Unit weight (not more), kgf		50000



UPR-100 is designed for overhaul repair, drilling, and deep wells development in moderate and cold (region 12) macroclimatic regions acc. to GOST 16350 with ambient temperature from - 45°C to 40°C.

Main design features and service advantages:

- high mobility during erection and dismantling operations by front and rear outriggers for rig up.
- derrick rear support is made as separate part thus excluding load moving towards unit chassis while operation;
- spring brake prevents tackle system from lowering during long stay;
- wide range of systems and units as per Customer's requirements (limit switch, rotary drive, rope bypassing mechanism, emergency drive, operator's platform, driller's station etc.)
- operations control from operator's cab as well as from driller's station;
- modified versions of the units with observed height clearance.

Supplementary equipment is provided as per Customer's requirement. Power swivel PS120 is also available (Logan oil tools Inc. USA, authorized distributor in Russia 'Neftepromservice').

Additional equipment- as per order. It can be equipped with PS120 power swivel (of «Logan Oil Tools «Inc. USA production; authorized distributor in Russia –LLC «Neftepromservice»).

Mounting base	RKR-63221-4320 (4-axis)
Hook loading capacity, kN (tf)	
- nominal	980 (100)
Height to crownblock axis, m	22,6
Derrick	Telescopic 2-section with open front side
Drive	from PTO by drive shaft
Derrick securing in operation position	hydraulic/remote
Hook traveling speed, m/s	
- max/min	1,42/0,15
Tackle system	8 string
- tooling	4x5
Primary draw works	Single-drum, wireline groove on drum
- dia of the hoist wireline,mm	25
Brake	strip-block
- brake pulleys number	2
Transmission	3-speed
Overall dimensions,mm	
- length	13400
- width	2550
- height	4500
Rig weight (not more than), kgf	40000

UPR-100

HOISTING UNIT FOR BOREHOLES DRILLING AND REPAIR ON PPS-5 SELF-PROPELLED CHASSIS BASE



It is designed for drilling of boreholes of 2500 m deep (with 24 kg/m spring mass) with rotor and bottomhole motor, overhauling, development and restoration of oil and gas boreholes up to 5000 m deep (tubing 14kg / m) in moderate microclimate regions at ambient air temperature from -45 ° C to +40 ° C

Basic design features and operational advantages:

- chassis is manufactured on the base of production vehicle chassis "Ural M" main units: IC-engine, gearbox, transmission, axles, suspension, carrier, control units.
- cabin – of KamAZ vehicle.
- increased competitiveness of special machinery due to lower prices compared to vehicles on vehicle chassis;
- permissible axle loads on the roads (5 axles);
- reliable engine, convenient for operation and maintenance (Euro-0, deck arrangement);
- multipurpose chassis for wide range of special machinery;
- good cross-country ability (4 drive axles, single-tire wheel).

Wheel arrangement	10x8
Engine	YAMZ-238M2
Emission standard	Euro-0
Rated power, kW (hp.)	176(240)
YAMZ clutch-182	friction, dry, single disk, with extension type diaphragm spring
YAMZ -2361 gear box	mechanical, three-pass, five-speed, synchromesh for 2-3 and 4-5
Traveling block loading capacity, kN (tnf)	
- nominal	1000 (100)
Height to crownblock axis, m	22,6
Derrick	telescopic, two-section, front open faced
- derrick securing in operation position	derrick guy system for fixing to outer anchors
Winch drive	from engine chassis
Main winch	mechanical single drum, with two brake rims
- wireline diameter, mm	25
Auxiliary winch	hydraulic
- force exerted rating, tnf	3,0
Gear box	three speed
Filling value - left/right	300/200
Inter-wheel and interaxial differentials	locking on 3,4 rear buggy axles
Overall dimensions, mm	
- length	13160
- width	2500
- height	4000
Total weight, kg	32160

The unit is designed for drilling by rotor and down-hole motors of boreholes 2500 m deep (with drill string 24 kg/m), for overhaul repair, development and rehabilitation of oil and gas boreholes up to 5000 m deep (oil-well tubing 14 kg/m) in moderate macroclimatic regions with ambient temperature from -45° C to +40° C.

Main design features and service advantages:

- high mobility during erection and dismantling operations due to availability of front and rear outriggers for unit rigging up;
- derrick rear support is made as separate part thus excluding load moving towards unit chassis during operation;
- spring brake in brake system prevents lowering- in of tackle block during long stay;
- the unit is equipped with racking platform, adjustable in three positions for double stands
- availability of different developed designs of systems and units for specific operating environment on the customer's choice («limit switch», rotary drive, rope bypassing mechanism, emergency drive, tubing anchor operator's platform, driller's station, catwalk and etc.).



Mounting base	MZKT 7004
Hook load capacity, kN (tf)	
- nominal	981 (100)
Height to crownblock axis, m	32
Derrick	telescopic, 2- section with racking platform
Derrick raising and extension	by hydraulic jack and hydraulic winch
Tackle system	8- string
- tooling	4x5
Winch	single drum, hydraulic with speed stepless remote control and band and shoe brakes
Electric equipment	24V
Working systems power supply	from automotive alternator through storage battery or from external power supply 220V through transformer and rectifier
Overall dimensions, mm	
- length	19500
- width	3000
- height	4500
Unit weight (not more), kgf	50000

UPRB-125

MOBILE HOISTING UNIT FOR BOREHOLES DRILLING AND REPAIR ON SEMITRAILER CHASSIS



Hoisting unit UPRB-125 for boreholes repair and drilling is designed for following operations:

- rotary and bottomhole drilling of boreholes 2700 meters below the ground surface (column mass 24 kg/m) as part of drilling facilities;
- overhaul repair, development, and reworking of oil and gas boreholes up to 5400 m below the ground surface (tubing pipes 14 kg/m);
- sidetracks kick-off.

Mounting base	Semitrailer SPTE 99130
Chassis motor	TMZ-8431.10 (470 h.p.)
Hoisting block loading capacity, kN (tf)	
- nominal	1226(125)
Height to crownblock axis, m	37
Derrick	Telescopic 2-section, original design, racking platform, tillable open front end audiovisual indication of upper section setting to slips
Raising and extension of the derrick	hydraulic jack and hydraulic draw works
PTO	from wheeled tractor
Hook traveling speed, m/s	
- max/min	1,5/0,15
Tackle system	8 string
- tooling	4x5
Primary draw works	Single-drum, double-band brake and pneumatic friction clutch of drum actuation, Lebus grooves
- dia of the hoist wireline, mm	28
Auxiliary draw works	hydraulic, remote control from driller's station
- loading capacity, tf	3,0
Brake	strip-block
- brake pulleys number	2
- brake control	pedal (pneumatic), manual (driller's station)
- hydraulic brake	actuation by disc air clutch
Emergency drive	electrohydraulic, 30kWt
Overall dimensions, mm	
- length	26500
- width	3100
- height	4500
Rig weight (not more than), kgf	70000

Note: UPRB-125 unit with electrical drive of main operating mechanisms and electromechanical top drive is available.



Hoisting unit UPRB-125 for boreholes repair and drilling is designed for following operations:

- rotary and bottomhole drilling of boreholes 2700 meters below the ground surface (column mass 24 kg/m) as part of drilling facilities;
- overhaul repair, development, and reworking of oil and gas boreholes up to 5400 m below the ground surface (tubing pipes 14 kg/m);
- sidetracks kick-off.

Mounting base	MZKT 7003
Chassis motor	TMZ-8431.10 (470 h.p.)
Hoisting block loading capacity, kN (tf)	
- nominal	1226(125)
Height to crownblock axis, m	37
Derrick	Telescopic 2-section, original design, racking platform, tillable, open front end audiovisual indication of upper section setting to slips
Raising and extension of the derrick	hydraulic jack and hydraulic draw works
PTO	from wheeled tractor
Hook traveling speed, m/s	
- max/min	1,5/0,15
Tackle system	8 string
- tooling	4x5
Primary draw works	Single-drum, double-band brake and pneumatic friction clutch of drum actuation, Lebus grooves
- dia of the hoist wireline, mm	28
Auxiliary draw works	hydraulic, remote control from driller's station
- loading capacity, tf	3,0
Brake	strip-block
- brake pulleys number	2
- brake control	pedal (pneumatic), manual (driller's station)
- hydraulic brake	actuation by disc air clutch
Emergency drive	electrohydraulic, 30kWt
Overall dimensions, mm	
- length	26500
- width	3200
- height	4500
Rig weight (not more than), kgf	70000

Note: UPRB-125 unit with electrical drive of main operating mechanisms and electromechanic top drive is available.

UPRB-125

MOBILE HOISTING UNIT FOR BOREHOLES DRILLING AND REPAIR ON BAZ CHASSIS



Hoisting unit UPRB-125 for boreholes repair and drilling is designed for following operations:

- rotary and bottomhole drilling of boreholes 2700 meters below the ground surface (column mass 24 kg/m) as part of drilling facilities;
- overhaul repair, development, and reworking of oil and gas boreholes up to 5400 m below the ground surface (tubing pipes 14 kg/m);
- sidetracks kick-off.

Mounting base	BAZ 69099
Chassis motor	YAMZ-843 1.10 (470 h.p.)
Hoisting block loading capacity, kN (tf)	
- nominal	1226(125)
Height to crownblock axis, m	37
Derrick	Telescopic 2-section, original design, racking platform, tillable, open front end audiovisual indication of upper section setting to slips
Raising and extension of the derrick	hydraulic jack and hydraulic draw works
PTO	from wheeled tractor
Hook traveling speed, m/s	
- max/min	1,5/0,15
Tackle system	8 string
- tooling	4x5
Primary draw works	Single-drum, double-band brake and pneumatic friction clutch of drum actuation, Lebus grooves
- dia of the hoist wireline, mm	28
Auxiliary draw works	hydraulic, remote control from driller's station
- loading capacity, tf	3,0
Brake	strip-block
- brake pulleys number	2
- brake control	pedal (pneumatic), manual (driller's station)
- hydraulic brake	actuation by disc air clutch
Emergency drive	electrohydraulic, 30kWt
Overall dimensions, mm	
- length	26500
- width	3200
- height	4500
Rig weight (not more than), kgf	70000

Note: UPRB-125 unit with electrical drive of main operating mechanisms and electromechanic top drive is available.



The unit is designed for boreholes routine repair, development and overhaul, as well as for drilling works by rotary system or downhole motors on various purpose boreholes: prospecting, hydrogeological, water-supply, producing (oil, gas) in moderate and cold macroclimatic regions with ambient temperature from -45°C to $+40^{\circ}$, location category 1 according to GOST 151510.

Transportation base, model	tri-axle semitrailer, double-tire wheel, SPTE99130
Allowable hook load with derrick guy lines on ground, kN (tf)	1400(140)
Characteristics, tn	
- loading capacity	56
- length, mm	20 000
- width, mm	2 500
Engine type	TMZ-8431.10, capacity - 470 hp
Winch, type	Single barrel, with disc air coupling, Lebus groove for even rope laying
- traction force, (tnf), not less than	19,5
- winch drive	Transmission with three-speed gear box and angle gearbox
- brake	Double-band brake, with lever-type equalizer, shoes 230x120 mm, brake chamber with spring actuator.
- hydromatic brake	Descent rate not more than 0.7 m/sec with weight on hook 85 t
- hook block hoisting speed, m/s	0,25-1,45
- winch block drive speed number, not less than	8
Derrick, type	two-section, 2- section derrick, tilting, front open faced, with derrick, lifting remote system
- number of sections	2
- height from ground level to crown block axis, m, not less than	37
- derrick lifting system	telescopic hydraulic cylinder
- head section extension system	drilling line system with hydraulic winch
Tackle system	with deadline anchor and dead end bypass mechanism
- tooling	4x5
- wireline diameter, mm	28
Hydraulic system	with one hydraulic tank and service fluid heating
Electric equipment	explosion-proof version in explosion hazardous zone
- voltage, V	24

UKPT-10

INTEGRATED COILED TUBING UNIT WITH PORTAL TYPE DERRICK



The unit is designed for maintenance repair of boreholes by sucker-rod insert pumps to replace downhole pumping equipment as well as to carry out bottom-hole area and borehole treatment, tubing washing, boreholes development etc. using coiled tubings.

Major design features and performance advantages

- coiled tubing and derrick-drawwork units combination allows carrying out boreholes repairing activities by single unit (tripping operations on downhole pumping equipment replace using derrick-drawwork unit as well as bottomhole treatment and tubing washing by coiled tubing unit);
- electrohydraulic control system implementation.

Transportation basel	Tri-axle semitrailer with YAMZ-238 deck
Power station deck power plant , hp	YAMZ-385 240
Overall dimensions in transport position , mm	
- width	2500
- length	20000
- height	4000
Maximum travel speed, km/h	50
Injector head pull capacity, kN	100
CTP drum capacity, m, at CTP diameter 31.75 mm	2000
CTP maximum travel speed, m/s	1
Maximum load on travelling block, t	8
Travelling block travel speed, m/s.	1
Travelling block lifting height, m	13,5



The unit is designed for injection of liquid media during grouting, preflush, overflush operations in the process of borehole drilling, development, and overhaul repair.

Climatic version-U, arrangement category I acc. to GOST 15150-69 at working temperature of ambient air from -40° to $+40^{\circ}$ C.

Mounting base	Semitrailer
Working medium	liquid mediums used for grouting, irrigating and forcing through works
Pump	Triplex plunger pump SIN32 (or NK500) - max. pressure 50Mpa - delivery, 11.5 hp (41 m ³ /h) Piston cementing pump TsN26-32 - piston travel 250 - globoidal gear ratio 20.5
Impeller pump - rotation frequency, not more than - feeding, not more than l/c - pump output pressure, not more than	TsNS – 38-154 49.16 c-1 (2950 rpm) 10,6 1,54 MPa
Measuring tank capacity, m ³	6
Nominal inside diameter of manifold pipes, mm - suction line - discharge line	100 50
Unit overall dimensions, mm, not more than - length - width - height	10870 2500 3300
Unit gross weight, (not more) kgf	15300
Weight of mounted equipment, kg	6400

ATs-32

CEMENTING UNIT WITH TRIPLEX PLUNGER PUMP



The unit is designed for injection of liquid media during grouting, preflush, overflush operations in the process of borehole drilling, development, and overhaul repair.

Climatic version-U, arrangement category I acc. to GOST 15150-69 at working temperature of ambient air from -40° to $+40^{\circ}$ C

Mounting base	URAL 4320	RKR 65053	RKR 63221	KAMAZ 43118
Working medium	liquid mediums used for grouting, irrigating and forcing through works			
Triplex plunger pump	NP-32			
- max. pressure MPa	50			
- pump delivery, l/c (m ³ /h)	11,5 (41)			
Impeller pump	TsNS – 38-154			
- rotation frequency, not more than	49,16c-1 (2950 rpm)			
- feeding, not more than l/c	10,6			
- pump output pressure, not more than	1,54 MPa			
Measuring tank capacity, m ³	6			
Nominal inside diameter of manifold pipes, mm				
- suction line	100			
- discharge line	50			
Unit overall dimensions, mm, not more than				
- length	10870	10200	10460	9450
- width	2500	2500	2500	2500
- height	3300	3160	3365	3300
Unit gross weight, (not more) kgf	15300	15160	15300	15000
Weight of mounted equipment, kg	6400	6400	6400	6200
Distribution of unit gross weight on the road, (not more) kgf				
- through front axle	5300	5600	5500	5600
- through rear axle	10000	9560	9800	9400



The unit is designed for injection of liquid media during grouting, preflush, overflush operations in the process of borehole drilling, development, and overhaul repair.

Climatic version-U, arrangement category I acc. to GOST 15150-69 at working temperature of ambient air from -40° to $+40^{\circ}$ C

Mounting base	URAL 4320	RKR 65053	RKR 63221	KAMAZ 43118
Working medium	liquid mediums used for grouting, irrigating and forcing through works			
Piston cementing pump	TsN 26-32			
- max. pressure MPa	40			
- pump delivery, l/c	26			
Impeller pump	TsNS – 38-154			
- rotation frequency, not more than	49,16c-1 (2950 rpm)			
- feeding, not more than l/c	10,6			
- pump output pressure, not more than	1,54 MPa			
Measuring tank capacity, m ³	6			
Nominal inside diameter of manifold pipes, mm				
- suction line	100			
- discharge line	50			
Unit overall dimensions, mm, not more than				
- length	10870	10200	10460	9450
- width	2500	2500	2500	2500
- height	3300	3160	3365	3300
Unit gross weight, (not more) kgf	15300	15160	15300	15000
Weight of mounted equipment, kg	6400	6400	6400	6200
Distribution of unit gross weight on the road, (not more) kgf				
- through front axle	5300	5600	5500	5600
- through rear axle	10000	9560	9800	9400

US 20x50, US 16

MIXING UNIT



The unit is designed for transportation of dry powder materials (cement, grouting mixtures etc.), for mechanical regulated feed of such materials by auger conveyor and preparation of grouting mixtures for oil and gas boreholes cementing.

Mixing Unit	US 20x50	US 16
Mounting base	KAMAZ 63501	KAMAZ 43118
Conveyed material admitted weight on hard surface road, t		
- hard surface	11,5	8
- other types of road surface incl. off-road conditions	7	6
Additional loading of bin at the place of cementing, t, not more than	25	20
Maximum output of grouting mixtures with density 1.85 g/cm ³ , dm ³ /s		27
Prepared mortar density g/cm ³		1,3-2,4
Time period for receiving prescribed density, s, not more than		40
Maximum output of dry cement, including		
- of feed auger conveyor		15,0
- of batching auger conveyor (rated output)		132,0
Auger conveyor drive	from vehicle additional power take-off and cardan shafts	
Unit control when mounting on KAMAZ chassis	from vehicle cab on control panel	
Bin capacity, m ³ , not more than	20	14,5
Mixing unit	hydraulic, vacuum	
- liquid optimal pressure, MPa		1,5
- liquid max. pressure, MPa		2,0

Unit transportation data

- max/ travel speed, km/h, not more than	60
- road clearance, mm	380

Unit overall dimensions, mm, not more than

- length	10000	8720
- width	2500	2550
- height	3900	3580

Technical permissible maximum chassis mass on road, kg, not more than

27200	21600
-------	-------

Distribution of unit total weight on road, kg

- 1st axle	5600	5800
- 2nd axle	5600	7900
- 3d axle	8000	7900
- 4th axle	8000	-





The unit is designed for collection of oil spilled, gas-condensate, oil product and nonaggressive process fluids as well as for their transportation for recycling.

Tank capacity, m ³	10
Tank net capacity, m ³	10±1,5%
Tank wall thickness, mm	6
Vacuum pump model	VK-6M2N
Vacuum pump delivery air discharge, m ³ /h	240
Maximum fluid mass of cargo liquid, t	10
Delivery-suction hose dia, mm	75
Suction depth	4,5
Maximum density of cargo liquid, g/m ³	1000
Vehicle curb weight, kg, not more than	11160
Oil skimmer gross weight, kg, not more than	21160
- on front axle	5520
- on rear bogie	15640
Max. pressure in tank, MPa (kgf/cm ²)	
- negative pressure	0,07 (0,7)
- overpressure	0,03 (0,3)
Time of tank filling using pump, min, not more than	20
Tank rundown time, min, not more than	
- using pump	15
- by gravity with open filler cap	30
Overall dimensions, mm, not more than	
- length	8700
- width	2500
- height	3750
Max. travel speed with curb weight on straight reach, km/h, not more than	90
Number of operative personnel, person	2

PISTON CEMENTING PUMP TSN 26-32 (ANALOGUE T9)

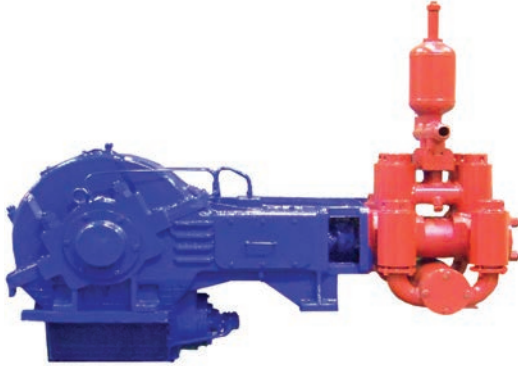

It is designed for boreholes cementing and is used on ATs-32 units.

Power, kW	108
Piston stroke, mm	250
Globoidal gear ratio	20,5
Working pressure, MPa	320
feeding, max l/c	26
Overall dimensions, mm	
- length/width/height	2354/794/1992
Gross weigh, kg	2684

TRIPLEX PLUNGER PUMP NP-32

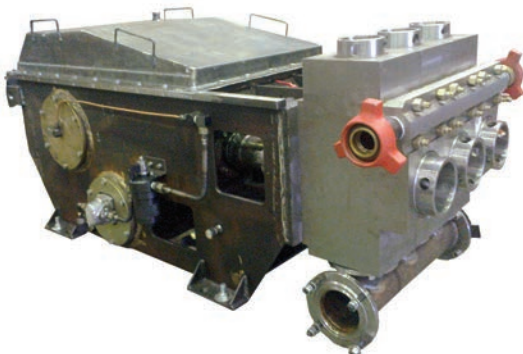

It is designed for boreholes cementing and is used on ATs-32 units.

Useful power, kW	110
Pump stroke, mm	160
Number of pump double strokes per minute:	
- max/min	260/ 40
Pump power end gear ratio	4,5
Pump-discharge pressure, Mpa, not less than	0,5
Overall dimensions, mm, not more than	
- length/width/height	1985/1025/910
Weight, not more than, kg,	2500

MECHANICAL ROTOR 80X400



Mechanical rotor 80x400:

- with chain RBK 80x400;
- with propeller shaft drive RB 80x400;
- with hydraulic drive RBG 80x400.

It is designed for rotation of drilling tool while drilling, repairing and developing of water oil and gas boreholes, as well as for cradling of drill strings, oil-well tubing or casings mounted on the elevator or in spider.

Rotary-table opening, mm	400
Permissible basic load on rotary table, not more than, t	80
Rotation torque on rotary table, not more than, rpm	1200
Rotary table speed of rotation not more than, rpm	200

MECHANICAL ROTOR R - 560

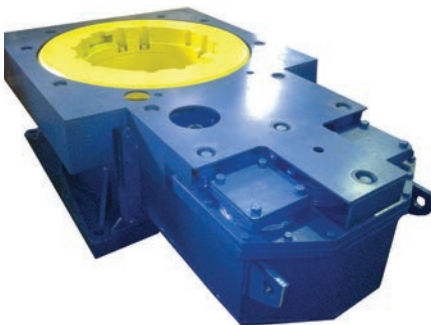

Mechanical rotor R 560:

- with mechanical drive R 560
- with hydraulic drive, rotor R 560-01.

It is designed for rotation of drilling tool while drilling, repairing and developing of water oil and gas boreholes, as well as for cradling of drill strings, oil-well tubing or casings mounted on PKR-560.

Rotary-table opening, mm	560
Power input, kW	150
Max. torque, kN	35
Basic load on rotary table, not more than, kN	2500
Max. rotation frequency, rpm	250
Table support	axial & radial bearings
Overall dimensions, mm	
- length/width/height	1727/960/567
Weight, kg,	2100

SPARE PARTS AND COMPONENTS

HOISTING UNIT SPARE PARTS

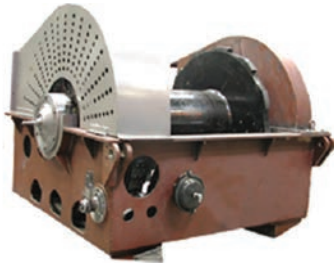

Hoisting winch

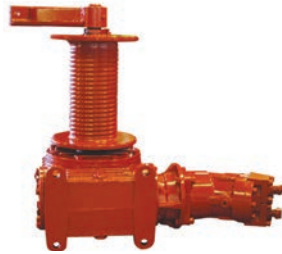

Auxiliary winch



Bevel gear speed reducer



Block hook



Single-axis crownblock



Telescopic derrick with open front side

HOISTING UNIT SPARE PARTS

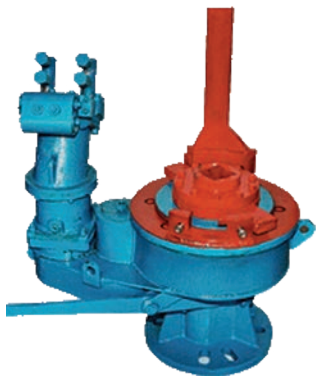

Rotor RM-200, R-250, R-360,
RU-80X400



Tongs GK-1500



Drilling swivels, tubing
swivels, water swivels

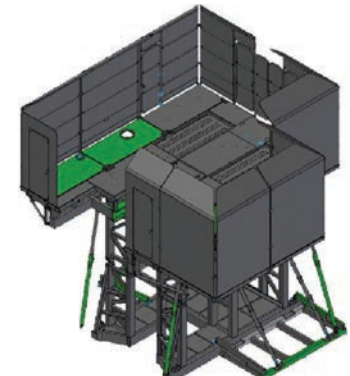

Power and mobile platforms
APRS-50, APR-60/80, APR-80,
UPR-100



Leading pipes



Elevator

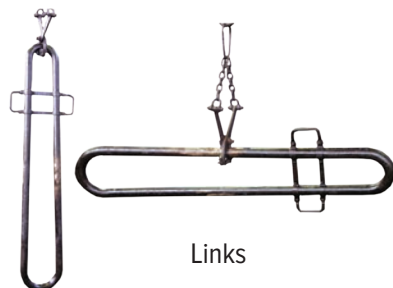

Links



Receiving temporary platform, on sleds or semitrailer

BACKHOE LOADERS



BACKHOE LOADER

ELAZ BL 880

**BACKHOE LOADER WITH ENHANCED
LOADING EQUIPMENT**

ELAZ BL 880

BACKHOE LOADER WITH CUMMINS ENGINE

ELAZ BL 888

BACKHOE LOADER WITH PERKINS ENGINE

ELAZ BL 888

BACKHOE LOADER

BOBCAT B-780

ELAZ-BL 880

BACKHOE LOADER



Backhoe loader ELAZ-BL 880 is multipurpose road and construction machinery that perfectly combines functions of bucket excavator and front loader. ELAZ-BL 880 is a new generation machine that implements optimal weight distribution, thereby providing safe, stable driving on highways and hard basis for digging.

ELAZ-BL 880 backhoe loader design implements different attachments used in construction, road construction, municipal, mining and oil sectors.

Cab is an important feature of ELAZ-BL 880 backhoe loader that provides safe and ergonomic operating space for operator.

Heavy-duty ELAZ-BL 880 backhoe loader unites strength and reliability.

Engine specification	Perkins 1104C-44T
Engine capacity max h.p.	100 h.p. /74,5 kWt
Excavating equipment	
Digging depth, max/min, mm	4600/5800
Dump bucket clearance, mix/min, mm	3850/4700
Dumping reach, mix/min, mm	1800/2650
Backhoe bucket capacity, m ³	0,18
Max. breakout force, backhoe, kN	59,4
Loading capacity at max. height of loader boom	3080
Loading equipment	
Loading bucket capacity, m ³	1,0 (6 in 1)
Bucket width, mm	2230
Loading bucket breakout force, kN	43,51
Dump height, mm	2740
Max. dumping reach, mm	1200
Levelling depth, mm	115
Overall dimensions, mm	
- length	5710
- width	2230
- height	3850
Operating weight, kg	7850
Front bucket control	mechanical
Backhoe control	mechanical
Hydraulic circuit	available
Advanced audio system	available
Differential lock system	available
Automatic return to dig	not available
Crab steer	not available



ELAZ-BL 880 is a new generation machine with optimal force distribution that ensures safe, stable driving at high-ways. ELAZ-BL 880 design allows installation of different attachments, implemented in road-building and municipal sectors.

Automatic transmission and axles Carraro, 4WD, ROPS/FOPS cab; mechanical levers ensure maximum operator comfort; advanced audio system, differential lock system, automatic return to dig; hydraulic circuit is available.

Engine specification	Perkins 1104C-44T, MMZ D-245 C
Engine capacity max h.p.	100 h.p. /74,5 kWt
Excavating equipment	
Digging depth, max/min, mm	4600/5800
Dump bucket clearance, mix/min, mm	3850/4700
Dumping reach, mix/min, mm	1800/2650
Backhoe bucket capacity , m ³	0,18
Max. breakout force, backhoe, kN	59,4
Loading capacity at max. height of loader boom	3800
Loading equipment	
Loading bucket capacity,m ³	1,0 (6 in 1)
Bucket width, mm	2280
Loading bucket breakout force, kN	55
Dump height, mm	2750
Max. dumping reach, mm	1060
Levelling depth, mm	115
Overall dimensions, mm	
- length	5790
- width	2280
- height	3850
Operating weight, kg	8280
Front bucket control	mechanical
Backhoe control	mechanical
Hydraulic circuit	available
Advanced audio system	available
Differential lock system	available
Automatic return to dig	not available
Crab steer	not available

ELAZ-BL 888

BACKHOE LOADER WITH CUMMINS ENGINE



Backhoe loader ELAZ-BL 888 is multipurpose road and construction machinery that perfectly combines functions of bucket excavator and front loader.

Automatic transmission Carraro, axles Carraro. 4 wheel drive. Comfortable cab with ROPS/FOPS protection. Mechanical levers provide highest possible convenience and simplify operator's performance.

Due to design reliability and hydraulic system efficiency the backhoe loader provides significant breakout and digging force. Its functional design ensures excellent dump height and digging depth as well as perfect visibility of job site.

Backhoe loader ELAZ-BL versatility is improved by use of plenty of additional equipment (telescopic stick, hydraulic hammer, extra buckets of different sizes, clamshell, etc.) used in construction, road construction, municipal, mining and oil sectors.

Engine specification	Cummins QSB 4.5-110
Engine capacity max h.p.	100 h.p. /82 kWt
Excavating equipment	
Digging depth, max/min, mm	4600/5800
Dump bucket clearance, mix/min, mm	3850/4700
Dumping reach, mix/min, mm	1800/2650
Backhoe bucket capacity, m ³	0,18
Max. breakout force, backhoe, kN	59,4
Loading capacity at max. height of loader boom	3800
Loading equipment	
Loading bucket capacity, m ³	1,1 (6 in 1)
Bucket width, mm	2400
Loading bucket breakout force, kN	77,2
Dump height, mm	2865
Max. dumping reach, mm	1620
Levelling depth, mm	115
Overall dimensions, mm	
- length	6375
- width	2400
- height	3900
Operating weight, kg	8840
Front bucket control	joystick
Backhoe control	joystick
Hydraulic circuit	available
Advanced audio system	available
Differential lock system	available
Automatic return to dig	available
Crab steer	available

ELAZ-BL 888

BACKHOE LOADER WITH PERKINS ENGINE



Backhoe loader ELAZ-BL 888 is multipurpose road and construction machinery that perfectly combines functions of bucket excavator and front loader.

Automatic transmission Carraro, axles Carraro. 4 wheel drive. Comfortable cab with ROPS/FOPS protection. Mechanical levers provide highest possible convenience and simplify operator's performance.

Due to design reliability and hydraulic system efficiency the backhoe loader provides significant breakout and digging force. Its functional design ensures excellent dump height and digging depth as well as perfect visibility of job site.

Backhoe loader ELAZ-BL versatility is improved by use of plenty of additional equipment (telescopic stick, hydraulic hammer, extra buckets of different sizes, clamshell, etc.) used in construction, road construction, municipal, mining and oil sectors.

Engine specification	Perkins 1104C-44T
Engine capacity max h.p.	100 h.p. /74,5 kWt
Excavating equipment	
Digging depth, max/min, mm	4600/5800
Dump bucket clearance, mix/min, mm	3850/4700
Dumping reach, mix/min, mm	1800/2650
Backhoe bucket capacity , m ³	0,18
Max. breakout force, backhoe, kN	59,4
Loading capacity at max. height of loader boom	3800
Loading equipment	
Loading bucket capacity,m ³	1,1 (6 in 1)
Bucket width, mm	2400
Loading bucket breakout force, kN	77,2
Dump height, mm	2865
Max. dumping reach, mm	1620
Levelling depth, mm	115
Overall dimensions, mm	
- length	6375
- width	2400
- height	3900
Operating weight, kg	8840
Front bucket control	joystick
Backhoe control	joystick
Hydraulic circuit	available
Advanced audio system	available
Differential lock system	available
Automatic return to dig	available
Crab steer	available

BOBCAT B-780

BACKHOE LOADER



Bobcat B-780 versatility is improved by using of plenty of additional equipment (telescopic stick, hydraulic hammer, extra buckets of different sizes, clamshell etc.) used in road construction and municipal sectors. Design reliability and hydraulic system performance capability ensure significant breakout force and backhoe digging.

Automatic transmission and axles Carraro, 4WD, ROPS/FOPS cab; mechanical levers ensure maximum operator comfort; advanced audio system, differential lock system, automatic return to dig; hydraulic circuit is available, crab steer.

Engine specification	Perkins 1104C-44T
Engine capacity max h.p.	100 h.p. /74,5 kWt
Excavating equipment	
Digging depth, max/min, mm	4600/5800
Dump bucket clearance, mix/min, mm	3850/4700
Dumping reach, mix/min, mm	1800/2650
Backhoe bucket capacity , m ³	0,18
Max. breakout force, backhoe, kN	59,4
Loading capacity at max. height of loader boom	3800
Loading equipment	
Loading bucket capacity,m ³	1,1 (6 in 1)
Bucket width, mm	2400
Loading bucket breakout force, kN	77,2
Dump height, mm	2865
Max. dumping reach, mm	1620
Levelling depth, mm	115
Overall dimensions, mm	
- length	6375
- width	2400
- height	3845
Operating weight, kg	8840
Front bucket control	joystick
Backhoe control	joystick
Hydraulic circuit	available
Advanced audio system	available
Differential lock system	available
Automatic return to dig	available
Crab steer	available



SPECIAL MACHINERY



UNIVERSAL ROAD TRUCK

UDM-80EC

UNIVERSAL ROAD TRUCK

UDM-80E

TRUCK MOUNTED CRANE-MANIPULATORS

KMA-E

WRECKER

EMERGENCY REPAIR KACHINE

ARM

**UNIT FOR REPAIR AND MAINTENANCE OF PUMP
JACKS**

AROK

MULTIPURPOSE DISINFECTION UNIT

UD-E

SHORT LOG TRUCK



UDM-80EC

UNIVERSAL ROAD TRUCK



The universal road truck on KAMAZ chassis is designed for all the year round maintenance of motor roads:

- cleaning of roadway and waysides from snow in high-speed regime;
- spreading of solid and liquid deicing agents on road surface;
- washing and watering of road surfaces and planted land.

The truck is supplied to customer in winter and summer versions on KAMAZ chassis and tippers.

Basic chassis	KAMAZ 65115 (6x4), KAMAZ 6520
MOUNTING EQUIPMENT	
Front angle blade with rubber blades	
- grasp width, mm	2600
- blade height, mm	1460
- working speed, km/h	40-60
Center broom	
- effective width, mm	2500
- broom dia, mm	550
Sand spreader	
- nominal capacity of bunker, m ³ , not less	7.0
- working width, m	2-10
Front angle blade, high-speed	
- effective width, mm/operating angle, degree	2700 / 43
- wing height, mm	1500
- working speed, km/h	45
Center blade with stump blade	
- grasp width, mm	2500
- working speed, km/h	40
Side blade	
- effective grasp width, mm	1850
- blade height, mm	1150
- working speed, km/h	up to 60
Washing equipment for hard guard rails	
- broom diameter, mm	900
- height of work surface, mm	270-1300
- working speed, km/h	6
Washing equipment for road signs and road furniture elements	
Water sprinkling equipment PO-10	
- tank capacity, m ³	10
- width of treated traffic lane, m	4-18
Tipping platform (for UDM-80ES)	
- capacity, m ³	10



The universal road truck on KAMAZ chassis is designed for all the year round maintenance of motor roads:

- cleaning of roadway and waysides from snow in high-speed regime;
- spreading of solid and liquid deicing agents on road surface;
- washing and watering of road surfaces and planted land.

The truck is supplied to customer in winter and summer versions on KAMAZ chassis and tippers.

Basic chassis	KAMAZ 65115 (6x4) KAMAZ 65115-1041
MOUNTING EQUIPMENT	
Front angle blade with rubber blades	
- grasp width, mm	2600
- blade height, mm	1460
- working speed, km/h	40-60
Center broom	
- effective width, mm	2500
- broom dia, mm	550
Sand spreader	
- nominal capacity of bunker, m ³ , not less	7.0
- working width, m	2-10
Front angle blade, high-speed	
- effective width, mm/operating angle, degree	2700/43
- wing height, mm	1500
- working speed, km/h	45
Center blade with stump blade	
- grasp width, mm	2500
- working speed, km/h	40
Side blade	
- effective grasp width, mm	1850
- blade height, mm	1150
- working speed, km/h	up to 60
Washing equipment for hard guard rails	
- broom diameter, mm	900
- height of work surface, mm	270-1300
- working speed, km/h	6
Washing equipment for road signs and road furniture elements	
Water sprinkling equipment PO-10	
- tank capacity, m ³	10
- width of treated traffic lane, m	4-18
Tipping platform (for UDM-80ES)	
- capacity, m ³	10

KMA-E

AUTOMOTIVE CRANE-MANIPULATORS



High duty crane- manipulators KMA-E of various loading capacity are designed for transportation of cargoes, loading and unloading, erection works, towing away of vehicles.

Trucks can be equipped with crane- manipulators: UNIC (Japan), Palfinger (Austria) HIAB (Sweden), FASSI (Italy), IN-MAN (Russia), Atlant-S (Russia, MMZ), BAKM (Russia) and others, with load moment up to 27 TM.

The following trucks are used as basic vehicle: KAMAZ-43118, KAMAZ-4308, KAMAZ-4326, KAMAZ-44108, KAMAZ-65117, KAMAZ-65116, KAMAZ-65115, URAL-4320, URAL -44202, KRAZ-65053, KRAZ-63221, USUZU, NPR75LK, NPR75LL.

Upon customer's request and depending on crane manipulator use it can be additionally equipped with removable attached implements (rotator, buckets, different grippers, auger etc.)





Emergency wrecker is designed for towing away of vehicles weighing up to 3.2 t

Damaged car loading on and unloading from platform is carried by hydraulic crane- manipulator.

Full revolving rotator and traverse used as load-handling fixture hold cars with different center of gravity in horizontal position. Additional rear stabilizers allow full use of crane loading capacity.

Special hooks fixed on the vehicle wheels are used for vehicle loading. Four wheel chocks that are fixed in the grooves of the platform are provided for vehicles transported on the platform. Eyelets (eyebolts) installed in the rear of the platform for strapping of vehicle with belts are used for long distance transportation of vehicle.

Basic chassis type	KAMAZ 4308
Truck weight, kg	6575
Overall dimensions, mm	
- length	8300
- width	2500
- height	3400
Gross vehicle weight, kg	11500
Loading capacity of vehicle, kg	3200
Length of being evacuated vehicle	5000
Gross weight load distribution, kg:	
- through front wheel tires	4350
- through rear wheel tires	7200



The truck provides welding, gas cutting, installation and dismantling, mechanical works; painting and repair of equipment and constructions up to 12 m high, in case of availability of quick-detachable cradle cage; transportation of various equipment, transportation of duty crew up to 5 persons.

Base chassis	KAMAZ 43114, URAL 4320-1912, KAMAZ 43118	
Wheel arrangement	6x6	
Curb weight, kg	14280	
Cargo weight, kg	4000	
Drop-side platform length, m	2.4	
Side height, mm	800	
Crane-manipulator	IM 150 T	Atlant LV 200
Load moment, tm	12.93	12
Max. loading capacity, kg	4310	2500
Max. radius of operation, m	7.0	8.8
Loading capacity at max. radius of operation, kg	950	1300
Max. lifting height, m	8.6	10.0



The truck provides welding, gas cutting, installation and dismantling, mechanical works; painting and repair of equipment and constructions up to 12 m high, in case of availability of quick-detachable cradle cage; transportation of various equipment, transportation of duty crew up to 5 persons.

Base chassis	KAMAZ 43114, URAL 4320-1912, KAMAZ 43118	
Wheel arrangement	6x6	
Curb weight, kg	14280	
Cargo weight, kg	4000	
Drop-side platform length, m	2.4	
Side height, mm	800	
Crane-manipulator	IM 150 T	Atlant LV 200
Load moment, tm	12.93	12
Max. loading capacity, kg	4310	2500
Max. radius of operation, m	7.0	8.8
Loading capacity at max. radius of operation, kg	950	1300
Max. lifting height, m	8.6	10.0



Disinfecting truck mounted on wheeled chassis is designed for direct application at temperature from 0 ° C to + 30 ° C, for storage and transportation at temperature from -45 ° C to + 40 ° C.

UNIT CONFIGURATION

The unit consists of the following main parts:

Metal tank 3 mm thick, divided into two compartments. Stock solution canisters are in the rear section.

Metal tank with heater and heat exchanger. Manometric thermometer TAP-100EK- M1 UHL4 with temperature sensor is installed for working solution control.

Working solution flare heater 144.8106- 30 operates from vehicle on-board power system.

Heater thermal output is 35 kW. Stock solution heater (with tubular heating element).

Plastic canisters for stock solution (12 canisters, 25 liters each), metal cans are available for supply.

Hand pump RK-2.

Vortexes pump VK 2/2.6.

The pump is driven by KOM 3512-4201010 through drive-shaft and V-belt transmission.

Valve unit includes pressure receiver, receiving manifold and valves

Working solution piping system.

Pressure hoses reel.

Suction hose at least 4.5 m long and with nominal bore 50 mm ± 2 mm, designed for water suction from basin.

Hand hose nozzle with interchangeable nozzles and hose with nominal bore 15 mm ± 2 mm, with hose 15 m long, for delivery of working solution to the place of disinfection. Spare parts case with the following dimensions in mm : (LxWxH) 310±3x3 10±3x46±3.

Operations carried out by hand fire nozzle:

1. Directed fluid jet washing:
 - length of horizontally directed jet, not less than 6 m at 0.3 MPa (3 kg/cm²) manometer pressure;
 - delivery (fluid consumption), 18 l/min;
 - temperature regime – up to 50 ° C.
2. Directed aerosol wet disinfection
 - spray angle, 60°;
 - delivery (fluid consumption) 12 l/min.

Operations carried out by stationary devices:

1. Treatment of sites by fluid jet:
 - fluid delivery termination devices- two slotted nozzles installed in front of the carrier vehicle; nozzles can be rotated and fixed in any position with respect to two mutually perpendicular axes. Nozzle rotational angle with respect to axis 90 °;
 - nozzles total delivery (fluid consumption) 40 l/min;
 - spray angle in the horizontal plane - 90°
2. Extensive treatment of facilities with aerosols:
 - fluid delivery termination devices- two aerosol sprayers installed in the rear of the carrier vehicle - media; sprayers may be rotated and secured in any position with respect to two mutually perpendicular axes. Nozzle rotational angle against axis 90 °;
 - nozzles total delivery (fluid consumption) - 20 l/min;
 - spray angle- 90°

Basic chassis	KAMAZ 4308
Crew, including the driver, people	2
Working solution amount in cistern and tank, l	4600
Stock solution amount in cans, l	300



Multipurpose disinfecting truck is designed for:

- wet disinfection and disinsection of cattle farms, warehouses and other covered premises with heated disinfecting solution directed jet and/or sprayed solutions;
- disinfecting of transport means after transportation of animals, as well as open areas (animal burying places, markets and other areas);
- washing of animals with heated disinfecting solution directed jet, brushes or shower nozzle;
- other works using water and/or alkali water solutions, organic or inorganic salts and other solutions.

The unit is available in climatic version «U» as per GOST 15150-69 for direct application at temperature from -10 to +50 degrees C and for storing and transportation of disinfectants water solutions.

Disinfecting units on ZIL chassis base are manufactured in the following modifications:

- main tank-2000 l,
- working solution preheat system
- equipped with burner nozzle
- with working solution mixing function

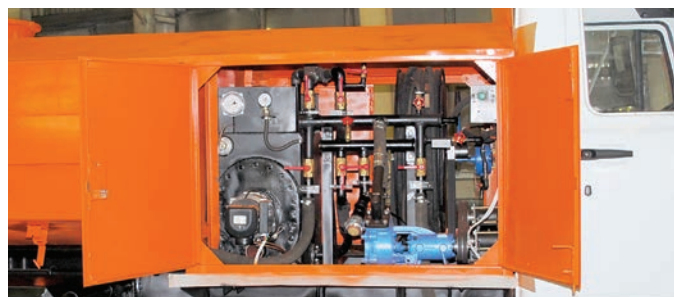

Unit model	UD-E
Mounting base	GAZ 3309
Overall dimensions, mm	
- length	6435
- width	2380
- height	2400
Engine type	diesel
Engine power kW (hp)	90 (122,4)
Curb weight of vehicle with working solution (kg)	6727
Crew, including driver (persons)	2
Working solution amount (kg) in tank	2000

SHORT LOG TRUCK



Short log truck with crane manipulator is designed for transportation of timbers from 2 m to 6 m long. The truck is equipped with special platform with bolsters and driver's cab protective shield.

Short log truck can be equipped with hydraulic manipulators produced by Maikop (MMZ), Velikoluksky (VELMASH), Zlatoustovosky machine-building plants and others.

Hydraulic manipulator configuration for short log truck: rotator with fork (forest chain grapples).

Hydraulic manipulators fitting position: behind the cab or on short log truck frame rear projection.

Short log truck hydraulic manipulator control: from operator's seat on crane pillar. It can be equipped with remote control panel as well.

Basic chassis type	KAMAZ 43118 KAMAZ 12500
Truck weight, kg	12500
Overall dimensions, mm	
- length	10150
- width	2500
- height	3950
Gross vehicle weight, kg	20100
Capacity of vehicle, kg	7600
Gross weight load distribution, kg	
- through front wheel tires	5800
- through rear wheel tires	14300



JSC «PA ELAZ» INDUSTRIAL SITE LAYOUT

Legend:

-  - Railway road
-  - Highway
-  - River port
-  - Railway station
-  - Airport

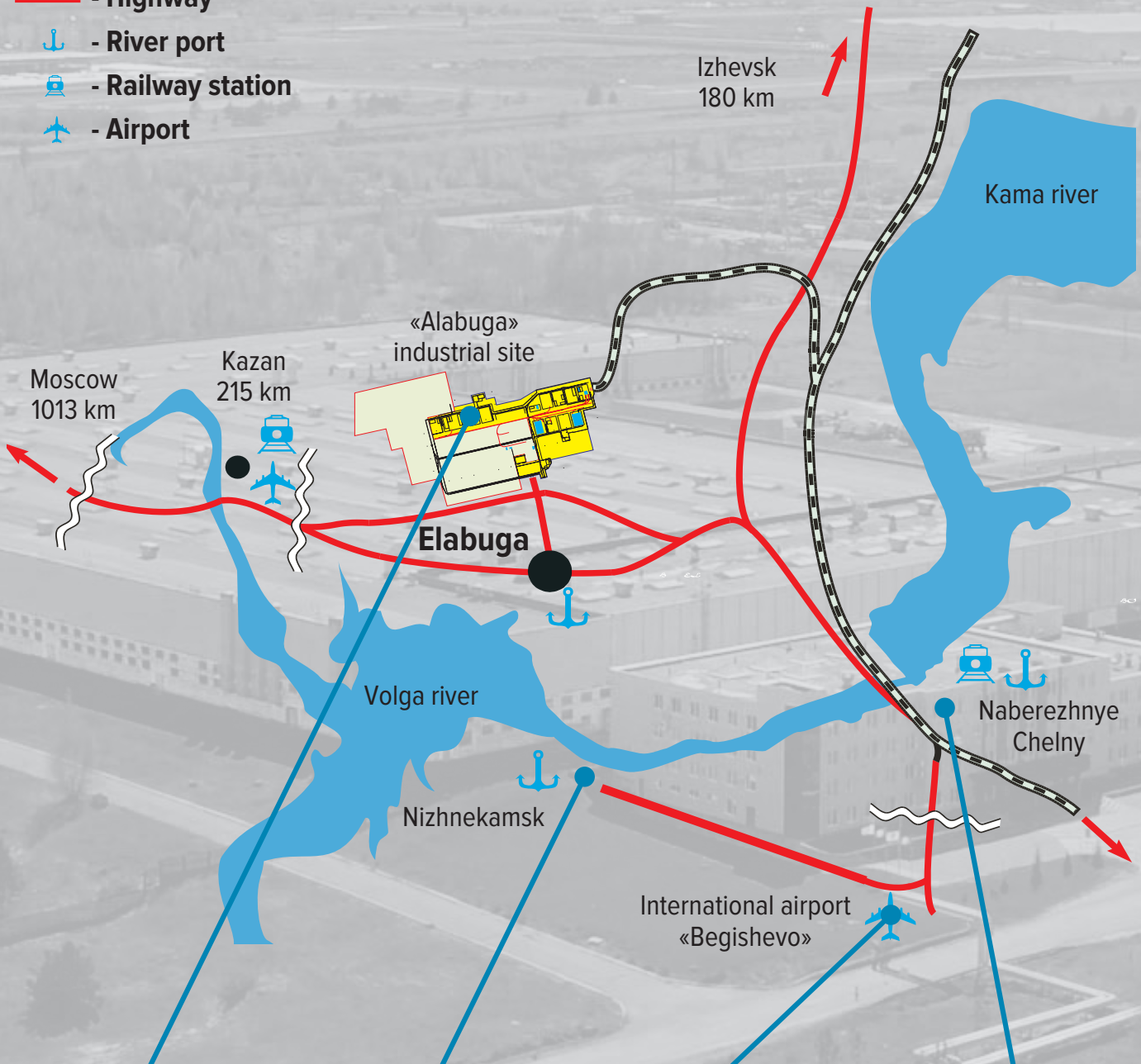



UPRB 180-225



Production Association
«Elabuga Automotive Works»

423600, Russia, Tatarstan, Elabuga,
«Alabuga» Industrial Site territory, 13 str.,
Producton base N° 6 of OJSC «PA ELAZ»

TRADE HOUSE ELAZ

tel.: +7 (85557) 5-58-66, 5-58-70, 5-58-59

fax: +7 (85557) 5-58-42

E-mail: tdelaz@elaz.ru

24/7 servicing and warranty maintenance

Tel.: + 7 (85557) 5-57-96, 5-56-02

+7-937-585-00-79, +7-927-470-30-51

E-mail: avzalov@elaz.ru, td-servis@elaz.ru

www.elaz.ru

8-800-700-16-25
Free call in Russia

